

## Notes from the Owners of Thin Air

Welcome aboard Thin Air! We're so excited that Thin Air is in the Pacific Northwest and part of the San Juan Sailing charter fleet. Thin Air started cruising in the Bahamas and Key West for two years before we realized that we really wanted to be based in the beautiful Puget Sound.

Thin Air performs well under sail and is perfectly suited for a group of friends or family to enjoy a week long cruise with the extra space a catamaran provides. The cabin layout provides some individual privacy (at least by sailboat standards!) and the kids love using the pilot berth. In addition, the galley and salon provide ample indoor space with large windows for the entire group to gather. The sliding doors open to the cockpit, creating an extended indoor/outdoor living area.

Once underway, you will immediately notice Thin Air's excellent handling and visibility. One of the best features on Thin Air is the 360 visibility from the helm station. Along with her twin props, this makes her extremely maneuverable around the marina and in other tight conditions.

We've added plenty of extras to make Thin Air a pleasure for everyone onboard, including:

- Helm station enclosure and diesel heaters to add comfort on those colder days
- Lots of storage for provision, a 150 liter fridge, and a separate 90 liter freezer
- Fusion stereo system that connects to your iPhone or other Bluetooth devices
- Garmin Radar and AIS were recently upgraded to improve overall safety and visibility to other vessels
- The list goes on, including solar panels, inverter, generator, and two fresh-water electric heads.

We make every effort to keep Thin Air in "like new" condition. We do have some basic rules we would appreciate you following, mainly no pets and no smoking. We sincerely hope you have a great time. If you have questions, or feedback, we would love to talk to you. You can reach us at 303-393-9193 (Vince's cell). Additionally, you can reach Abram (Turn Point Marine), Thin Air's maintenance pro, at 917-543-9627 (cell).

Enjoy your trip!  
Vince, Anika, & Ashley

**Thin Air Specifications:**

Year: 2015

LOA: 39' 3" LWL: 37' 5"

Beam: 22 1" Draft: 3' 10"

Displacement: 15,200 lbs (dry)

Mast height above WL: 60' (with antenna)

Fuel: 79 gal. (1 tank)

Water: 140 gal. (1 tank)  
Hot water: 10 gal.

Holding: 13 gal. for each head

Engine: Twin 20 hp. Volvos

**Other useful measurements:**

Refrigerator

- Main compartment: 150 liters

- Freezer compartment: 90 liters

Berth mattress sizes

- Fwd Berths: 6' 6" L by 5' 0" W

- Quarter Berths: 6' 5" L by 5' 2" W

Headroom: Fwd Berths 6' 5", Salon 6' 6",

Shower 6' 5", Quarter Berths 6' 10"

**TABLE OF CONTENTS:**

- |                                      |                                  |
|--------------------------------------|----------------------------------|
| 1. Emergencies and Safety Equipment  | 12. Fuel Tanks and System        |
| 2. Anchors & Windlass                | 13. Galley                       |
| 3. Barbecue                          | 14. Heads and Holding Tanks      |
| 4. Berths                            | 15. Refrigeration                |
| 5. Cabin Heat/ Air Conditioning      | 16. Repairs (Tools & Spares)     |
| 6. Dinghy & Outboard                 | 17. Sails and Rigging            |
| 7. Docking                           | 18. Showers                      |
| 8. Dodger & Bimini                   | 19. Stove                        |
| 9. Electrical Systems                | 20. Water                        |
| 10. Electronics                      | 21. What's Unique about Thin Air |
| 11. Engine and Operating Under Power |                                  |

***Key to Markings:*** Throughout these notes we have use the following convention:

- ***Italics*** – used for headings.
- **ALL CAPS** – used for safety and operational warnings.
- **Underlining** – indicates the location of things.
- **Bold** – indicates important knowledge or data.

## 1. *Emergencies and Safety Equipment:*

**Fire** – There are three ABC rated fire extinguishers onboard. They are in multiple locations, each berth under the bunk and several visible in the salon. All are ABC fire extinguishers. If you have a fire at the stove turn off the gas solenoid switch below the oven.

**Hitting a Log or Running Aground** – In case of a log hit or running aground, immediately check for leaks in the bilge and then check for cracks in the fore and aft sections of the bilge where the keel attaches to the hull. Also check all keel bolts. Once you are sure no water is entering the hull contact **San Juan Sailing at 800-677-7245** and proceed to the nearest harbor and have a professional diver check the hull, keel, prop, and rudder before proceeding.

**Leaks** – Make sure the bilge pumps are running. Then determine the source of the water, check the prop shaft first and then the through-hulls. Get the crew on deck and into life jackets. There are wood plugs wired to each of the through hulls.

There are four bilge pumps, one in each engine compartment one under the sole in each aft berth. All four have their own breaker on the 12 volt panel. The manual bilge pump is located on the stern walk-thru just across from the dinghy and behind the cockpit table seat.

**Steering Failure** – If the steering system fails there is an emergency tiller in the aft cockpit seat locker. It fits on rudder post which is accessed through the cap forward of each engine compartment. You will want to reduce sail or power when using this tiller since the tiller is small.

**Emergency Equipment** – Flares, air and manual horns, etc. under the nav table seat.

**Crew Overboard** – Throw a Type IV PFD or cockpit cushion to the person in the water first. Second, hit the COB button on the chart plotter so you will know where they are. Then use one of the procedures discussed in the skipper's meeting to get back to the person. We keep the LifeSling mounted on the stern rail, port side, at all times.

## 2. *Anchors and Windlass:*

Thin Air is equipped with two anchors, one forward (33# Delta with 175' of chain and 125' of rode) and a Fortress in the side of the anchor locker along with 15' of chain and 150' of rode. The chain on the primary anchor has the following length markings: 2' lengths of yellow line woven into chain, 1 piece every 25' and 2 pieces at 100' and 200'.

The scope normally used in the islands is 4 to 1, definitely not 7 to 1 (unless conditions call for it, i.e. sustained winds over 25 knots). Most of the anchorages are well protected and popular, so you will likely have someone anchored nearby. After you have paid out the suitable amount of chain, 1-2 minutes of reverse sets the anchor. **Here is an easy formula for how much chain you need out; add the water depth on sounder, plus any tide increase expected during the night, plus 5' (to account for the distance from sounder to roller on bow) and take that total and multiply by 4 (typical example would be 25' of water + 6' of tide increase + 5' = 36' x 4 = 144').**

The circuit breaker for the windlass is in the port engine locker (see picture under Batteries). **Please note the engine or generator needs to be running for the windlass to run.**

The up-down controller for the windlass is secured inside the anchor locker. **Be sure to take the tension off of the windlass by attaching the snubber to the chain and then running out more chain until the chain on the drum is slack.** Detailed operating instructions are listed below:

**Lowering the anchor:**

- a. Lower the anchor until the needed chain is paid out.
- b. Secure the chain with the snubber and run out enough chain to take the load off of the windlass.  
DO NOT LEAVE THE LOAD ON THE DRUM.
- c. Set the anchor by reversing at 800-1000 RPM for 1-2 minutes.
- d. If appropriate, turn on the anchor light.

**Raising the anchor:**

- a. Start the engine.
- b. Take in enough chain to retrieve the snubber.
- c. When retrieving the anchor, never use the windlass to pull the boat; instead, slowly power toward the anchor while using the windlass (up button on the remote control) to take up the slack. Also, if the anchor is really stuck in the mud you will hear the windlass slow under the load. Immediately stop the windlass and drive the boat forward to free the anchor.
- d. The incoming chain may pile up against the aft end of the chain locker so eyeball the pile occasionally.
- e. **Once the anchor is out of the water please bring onto the boat by hand.** Please do not pull the anchor up onto the rollers using the power of the windlass, doing so will likely chip the fiberglass as the anchor swings.

**Stern Ties:** There are times when adding a stern tie to shore will be handy, especially in Desolation Sound and further north. Thin Air has **600' of line on a spool** for this purpose, it is stored in the cockpit locker.

3. **Barbecue:** The stainless steel propane barbecue is mounted on the stern pulpit. Propane is supplied by a separate tank located under the aft seat of the cockpit table. Please be sure to turn the tank off when you are done cooking.
4. **Berths:** Thin Air sleeps nine; two in each of the four staterooms and one in the forepeak on the port side. All four of the double berths are quite roomy, each about equal to a queen bed. Please note the forepeak is not large and may be best suited for a child.

The dinette table in the salon converts to a large berth for additional sleeping area. See instructions below and the photo on right of the table legs conversion. If the filler cushion that goes on top of the lowered dinette table is not on board in one of the staterooms, then please contact the SJS office and they will retrieve it for you from the storage locker. In addition, let the office know if you'll need bedding for the conversion.



Lowering the dinette table:

- a) Loosen the black thumb screws near the base of each table leg (the thumb screws are attached to the middle sections of the legs).
- b) With one person at each end of the table, gently lift the table straight up and set back down upside down on the settee cushion.
- c) Remove the middle section leg extensions by loosening the thumb screws on the top section of the legs.
- d) Store the leg extensions under the settee seat.

- e) Replace the table onto the base legs and tighten the thumb screws on the base legs.

## 5. *Cabin Heat/Air Conditioning:*

**Furnace** – The Wabasto hydronic boiler is diesel fueled and the main On/Off switch is located to the right of the main panel, below and right of the radio mic. There are a total of five thermostats, located in each of the four cabins and also in the main salon, to the right of the freezer. Simply turn on the switch at the nav table then turn on thermostat in the cabin where heat is desired and set the temperature you want.

Be aware the Wabasto is sensitive to low voltage – if the batteries get run down too low (below 12.2ish) the system will lock and require a reset, call the maintenance pro listed in the boat binder to do so.

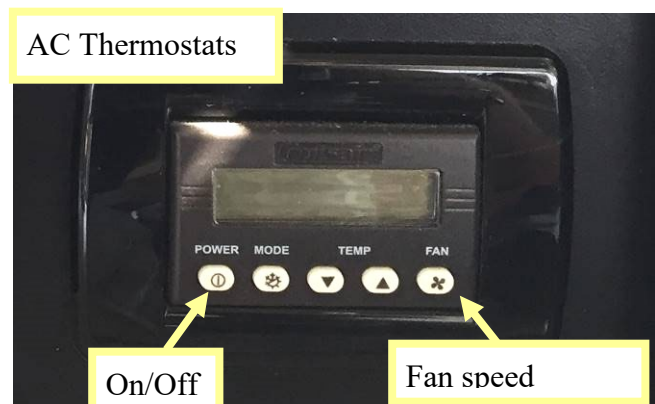

**Air Conditioning** – There are three separate air conditioning units, one for the salon and one for each hull. There are thermostats in each cabin and one under the 110-volt panel. All the thermostats are the same, see picture to right.

To turn on any of the AC systems the AC water pump needs to on first. Then 110 breaker for the appropriate system needs to be turned on. Lastly, turn on the thermostat and set desired temperature.

6. ***Dinghy and Outboards:*** Thin Air is equipped with a 10' Achilles hard bottom dinghy and a 9.9 hp Yamaha. The dinghy is roomy (easily holds 4 adults) and the outboards are easy to operate. The dinghy hangs on davits between the two hulls aft of the cockpit. There is a winch to aide in lifting the dinghy should you find it helpful.

As owners, we would very much appreciate your special care when beaching the dinghy. Beaches in the San Juans are seldom gentle, sandy beaches; often they are rocky and covered by barnacles equipped with extra sharp rubber cutters. So any extra care will be appreciated.

***Raising and lowering the Dinghy:*** Proper stowage of the dinghy is important from a safety perspective while sailing, especially in rough conditions. The dinghy should be raised to the maximum height and hanging as level as possible from the davits. This prevents waves from catching the dinghy as they pass between Thin Air's two hulls.



**The outboard is a four stroke engine, so no oil in the gasoline – they use straight gasoline.**

**Yamaha 9.9 hp Operating Instructions:** This outboard is pretty standard and intuitive to operate. Tilting it is probably the main exception to this. Therefore, we have included the manufacturer’s instruction for this area on the next page.

**Starting the Outboard**

- a. Attach the fuel tank hose to the motor and pump the bulb until firm. Also, be sure air vent on fuel tank is open.
- b. Make sure the black U-shaped kill clip (with the red lanyard) is clipped into the red shut-off knob (port forward corner of the outboard).
- c. Pull out the choke (starboard forward corner of the outboard) and push the rubber fuel priming button on the motor several times (not the bulb in the fuel line).
- d. Pull the cord until it starts (usually first or second pull).
- e. Once the engine is started move the ‘wheel lock’ lever to the right to free up the steering.

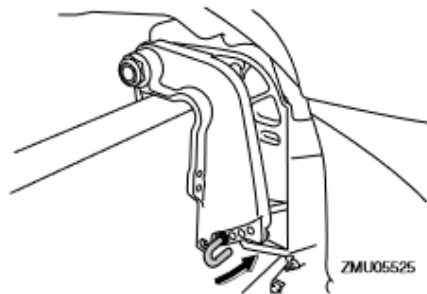

EMU30530

**Tilt lock mechanism**

The tilt lock mechanism is used to prevent the outboard motor from lifting out of the water when in reverse gear.

the release position.

EMU26320

**Tilt support knob**

To keep the outboard motor in the tilted up position, push the tilt support knob under the swivel bracket.

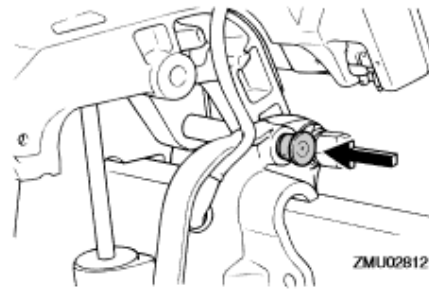

ZMU02812

EMU26330

**Tilt support bar**

The tilt support bar keeps the outboard motor in the tilted up position.

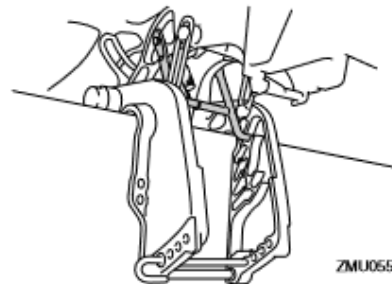

ZMU05528

EMU26360

**Power tilt unit**

This unit tilts the outboard motor up and down and is controlled with the power tilt switch.

ECM00630

**CAUTION:**

**Do not step on or exert pressure on the power tilt motor. The power tilt unit could be damaged as a result.**

Wheel lock (swivel) lever

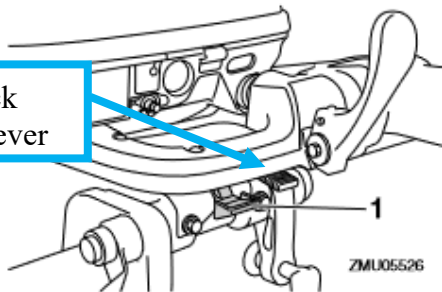

ZMU05526

1. Tilt lock lever (Lock / tilt-down)

Push this lever down to tilt.

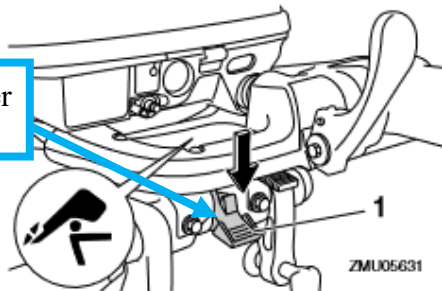

ZMU05631

1. Tilt lock lever (Release / tilt-up)

To lock it, set the tilt lock lever in the lock position. To release, push the tilt lock lever in

7. **Docking:** Thin Air has a relatively high freeboard which will create some sideslip in heavy winds. But with twin engine maneuvering around the docks it pretty easy. **The main thing to remember is the rudders are in front of the propellers so prop-wash can only be created in reverse.** While docking or maneuvering in tight spaces, you will want to steer using the twin engines, rather than the rudders. Using the two engines to steer makes Thin Air extremely maneuverable, essentially allowing her to rotate on her axis if placing one engine forward and one in reverse. However, **extra caution must be taken to hold the steering wheel and the rudders in place whenever the engines are placed in reverse – usually with your foot, knee, or body. Failure to keep the rudders and steering wheel centered while in reverse will cause damage to the steering mechanism and the rudders.**
8. **Dodger:** Thin Air has a dodger surrounding the helm seat. As with all dodgers, please be gentle. If the glass becomes spotted with salt please get a pot of fresh water from the galley sink and “flood” the salt crystals off the plastic. The salt crystal will scratch the glass if a rag is used.

## 9. *Electrical Systems:*

**Batteries** – Thin Air has **5 batteries onboard**, one for starting each engine, one for the generator and two 8Ds to power the cabin accessories. We have her wired for maximum convenience. These four battery systems are separated from each other by combiners so it should be impossible to drain the start battery.

### *Charging the Batteries:*

#### *1. Shore Power*

- Connect the shore power cord from Thin Air to the dock outlet. (Check cord placement to be sure the cord is not draped over the heater exhaust.) Flip on the dock breaker.
- Flip on the SHORE MAIN breaker on the AC Panel (located above the nav table, see photo below). The AC volt meter (Line Voltage) should read 120V.
- Flip on the CHARGER/INVERTER breaker on the AC Panel.
- Flip the toggle switch on the DIGITAL MULTI CONTROL panel to the right to “charger only” (small panel located below the nav table on the upper left, see photo below).
- Confirm batteries are charging – DC volt meter on upper left corner of DC panel should read 13+ volts. If reading less than 13 volts then not charging. Re-check above steps.

#### *2. Engine*

- All batteries are charged automatically while the engines are running at cruising RPMs.

#### *3. Generator*

- All batteries are charged automatically while the generator is running and the GENERATOR breaker on the AC Panel is flipped ON (located above the nav table, see photo below). The AC volt meter (Line Voltage) should read 120V.

#### *4. Solar Panels*

- All batteries are charged automatically by the solar panels when there’s adequate sunshine.

**Generator** – Thin Air has a 6 kW generator located under the port aft berth. The generator can be used to charge batteries, run the air conditioning, or power the all-important coffee maker when not on shore power. The starting sequence for the generator is listed below:

- a. Turn off the shore power breaker, slide the protector and turn on the generator breaker (see picture of 110V panel on next page).
- b. Press and hold the button on the generator panel located under the nav table.

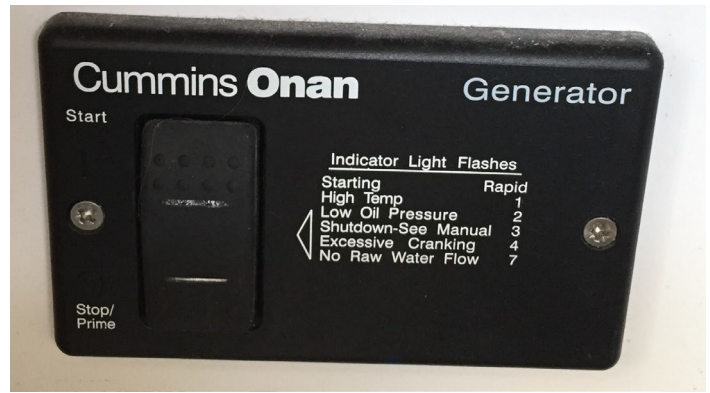

To stop the generator simply reverse the process.

**Solar Panels** – The solar panels are installed on top of the coach roof and over the dinghy and are capable of 560 watts. This is enough power to keep the batteries up to full charge when sitting at anchor, assuming ‘normal’ systems usage, i.e. the stereo, light, the heater, etc. and some sun. It will allow limited use of the inverter; say to run the microwave for a minute or two to warm something up. The system is self-controlling and should not require any attention.

**Inverter/Battery Charger** – We have installed a **2000-watt inverter** so 120V power can be used at any time. Be careful as it is easy to draw the batteries down. **We suggest leaving the inverter turned off unless you need 120V power; the main risk is running the house batteries low without realizing it.** The inverter control is located under the nav table, just above the generator controller. When the switch on the bottom is left the inverter and charger are on, centered both are off and to the right only the charger is on.

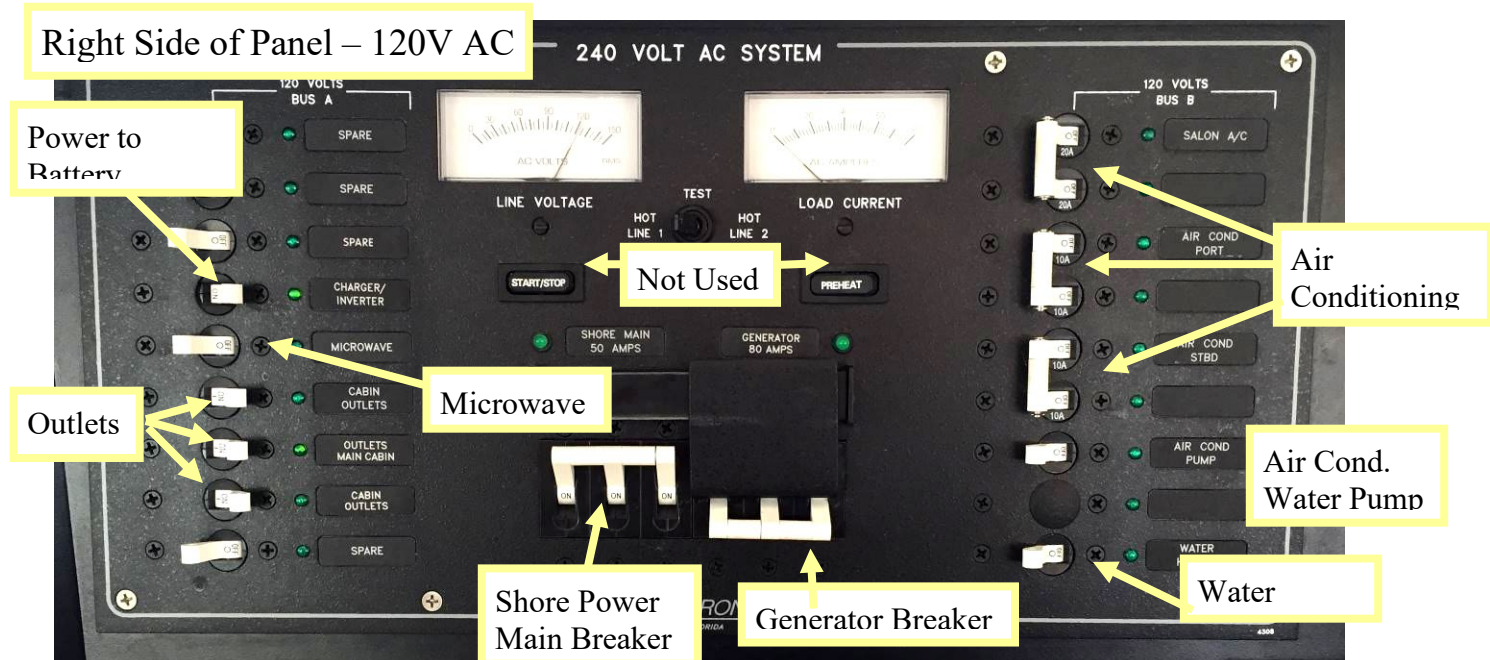



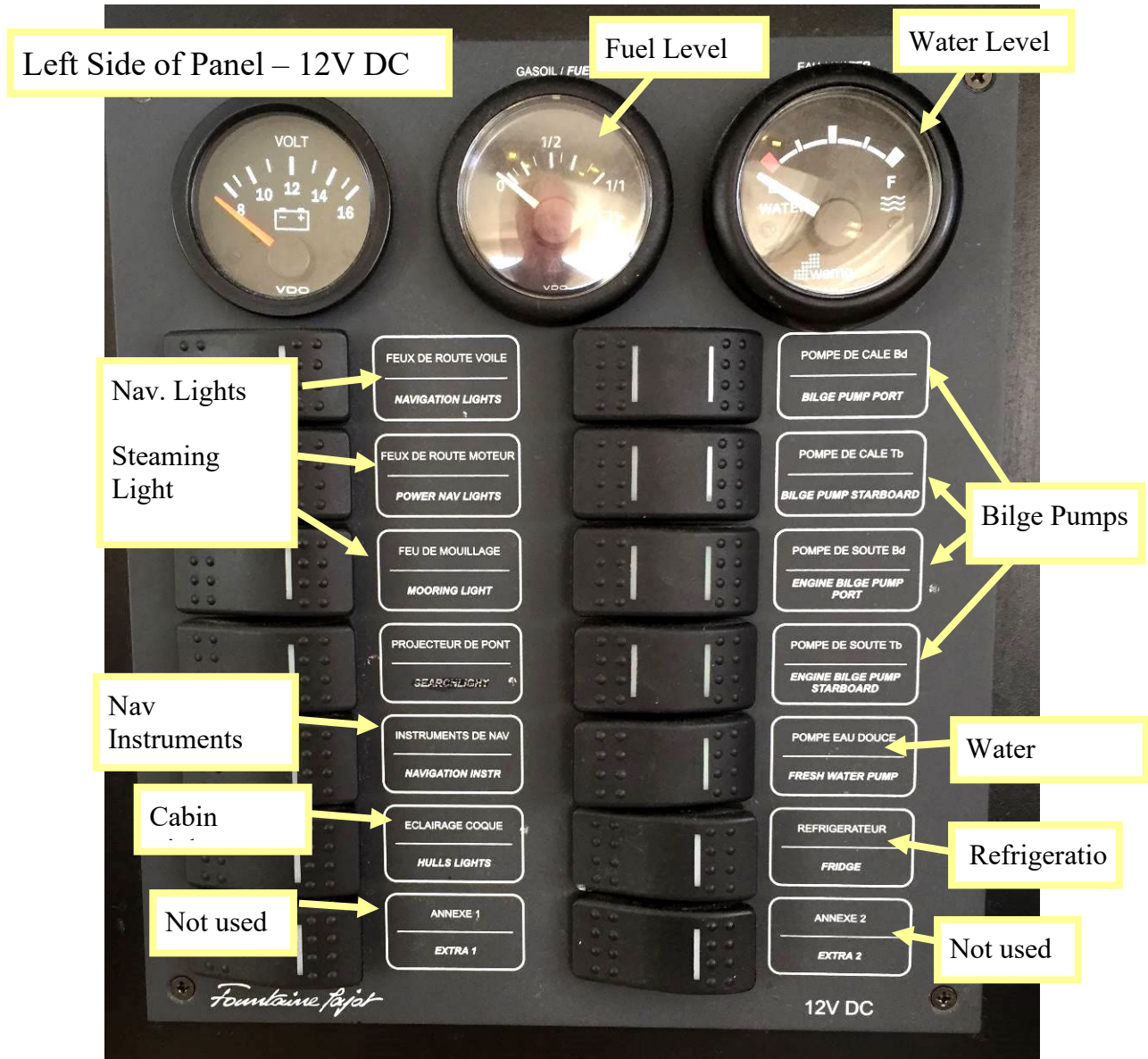

**Phone/ Device Charging** – There are two 12 volt and one USB outlets to the right of the main panel. There are also 110 AC outlets in this same area, in the galley and in each of the cabins.

The electrical panels on Thin Air are straight forward and clearly marked. When you leave the boat at the end of your trip the only 12V switch that needs to be left on is the refrigerator. On the 110V panel the battery charger on the right should be on (the outlets can be left on if desired).



There are additional breakers in the port engine compartment, see picture below:

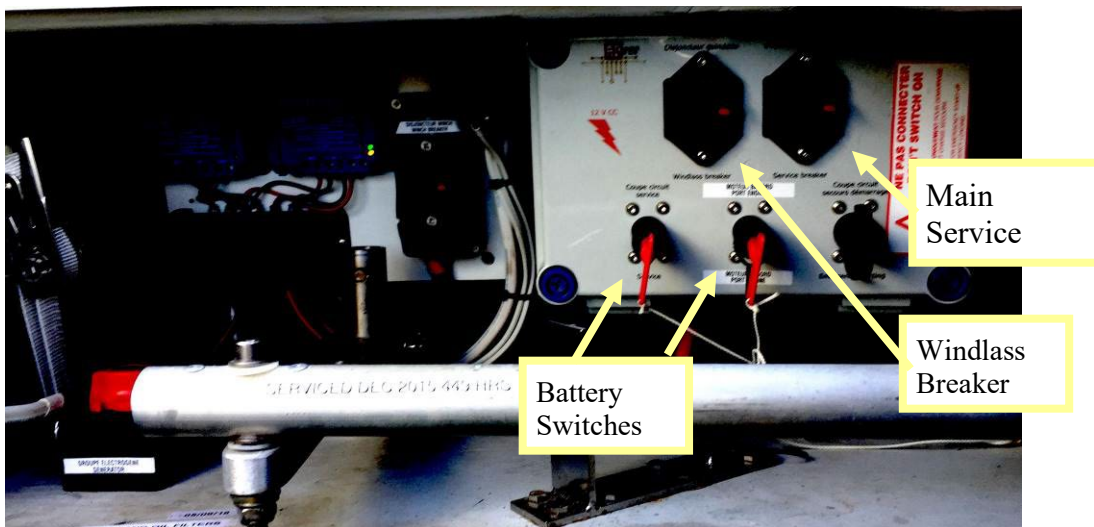

## 10. Electronics/Instruments:

**Phone/Device Charging** – There are two 12-volt cigarette lighter type outlets and one USB plug in the salon, just to the right of the main panel. Also, since we have an inverter you can charge using a normal 110-volt charger. Cell phone coverage is good around Bellingham, Friday Harbor and Roche Harbor. It is spotty elsewhere.

**Chart Plotter** – We have color chart plotters installed at the helm and on the main panel. The “Nav Instruments” breaker must be on at the electrical panel power the units.

We recommend that your PRIMARY navigation tool be the Maptech waterproof chart book or paper charts (both have the most active “killer rocks” marked in red). The best way to stay off the rocks is by knowing where you are at all times. The primary role of the chart plotter is to verify that you are where you think you are. And, when in a tight place it will allow you to zoom in for a better view than the real charts provide.

**Depth Sounder** – The digital depth sounder will not give accurate readings beyond 400’. In deeper water, the sensitivity on the unit increases as the transducer tries to get some reading back. Consequently, when you are in deep water false readings caused by currents, changes in water temperature, fish, etc. are common. These false reading often report very shallow water so knowing you are in deep water will prevent momentary heart attacks. The depth showing on the sounder is being measured from the transducer (about 18” under true water level) so the water under the boat is really a bit deeper than the reading. But, we strongly recommend leaving 10-12 feet of water under the boat.

We suggest using the depth sounder mainly as an aid to navigation in shallow water. However, the key to avoiding rocks is not the depth sounder – but knowing where you are on the chart at all times. ROCKS ARE THE SINGLE BIGGEST NAVIGATIONAL AND SAFETY HAZARD IN THE ISLANDS – BUT THEY ARE ALL MARKED ON THE CHARTS. We do not recommend using the alarm. Experience in the islands tells us that it goes off at the wrong time – usually the middle of the night as a seal or fish passes underneath.



**Knot Meter** – If the digital knot meter shows a reading of “0.00” while underway, the impeller is most likely clogged. Sometimes it will clear its self; wakes from big powerboats are good for this. You can also try clearing it by traveling in reverse. The instrument transponders are under the forward end of the sole in the port forward berth. You can remove the impeller to clear it but only if you are experienced in such things. The SOG (speed over ground) on the chart plotter will work as a standby knot meter if needed.

**A.I.S.** – Thin Air is equipped with an Automatic Identification System that is integrated with the Chart Plotter. This system will show most commercial vessels on chart plotter screen as triangles. The triangle points in the direction that vessel is moving and if you move the cursor over the triangle the system will give you addition information (such as name, size, speed, etc.) about the vessel. This system transmits and receives, enabling other vessels equipped with and AIS system to see your position.

**Radar** – Thin Air is equipped with a Garmin Radar that is also integrated with the chart plotter. It is operated through the Chart Plotter’s main screen and can be configured as needed based on the weather and sailing conditions.

**Stereo** – We have installed a good quality stereo under the electrical panel and with speakers in the cabin and cockpit. Please be aware of other boats when you are in harbor and adjust the Fader so that

the cockpit speakers are turned off when not in use. Also, if you have your own music this system can take input via Bluetooth.

**VHF Radio** – The main radio is mounted at the nav station and a RAM mic is mounted in the cockpit. There is also a hand held unit for use in the cockpit, the dinghy or ashore.

**We recommend that you monitor Channel 16 during your cruise.** It is reserved for emergencies and boat-to-boat initial contact. After contact, move to channels 68, 69, 72, 74 or 78. We listen to weather channels 1, 2, 3, 4 or 8 (whichever gives the best reception) before we sail in the morning and prior to anchoring for the evening. Listen for the reports identified as “Northern Inland Waters”. **San Juan Sailing monitors channel 80** during office hours (closed Sundays).

**2-way Radios** – Thin Air is also equipped with two hand-held radios that can be used for communication between Thin Air and crew that may have taken an excursion on the dinghy, or hiking onshore. They can also be useful communicating between the cockpit and crew on the bridgedeck when anchoring.

**Wind Instruments** – Wind speed and direction are displayed at the helm.

## 11. Engine and Operating Under Power:

**Operation** – We have found the **20 HP Volvo engines** to be very reliable. **Cruising should be done at engine RPMs of 1900 to 2400** (the boat feels most comfortable to us at 2200 to 2300). The following table gives approximate cruising information:

RPM's	Boat Speed	Fuel Consumption
2000	5 Knots	Approx. 0.6 gal/hr
2200	5.5 Knots	Approx. 0.7 gal/hr
2400	6 Knots	Approx. 0.8 gal/hr

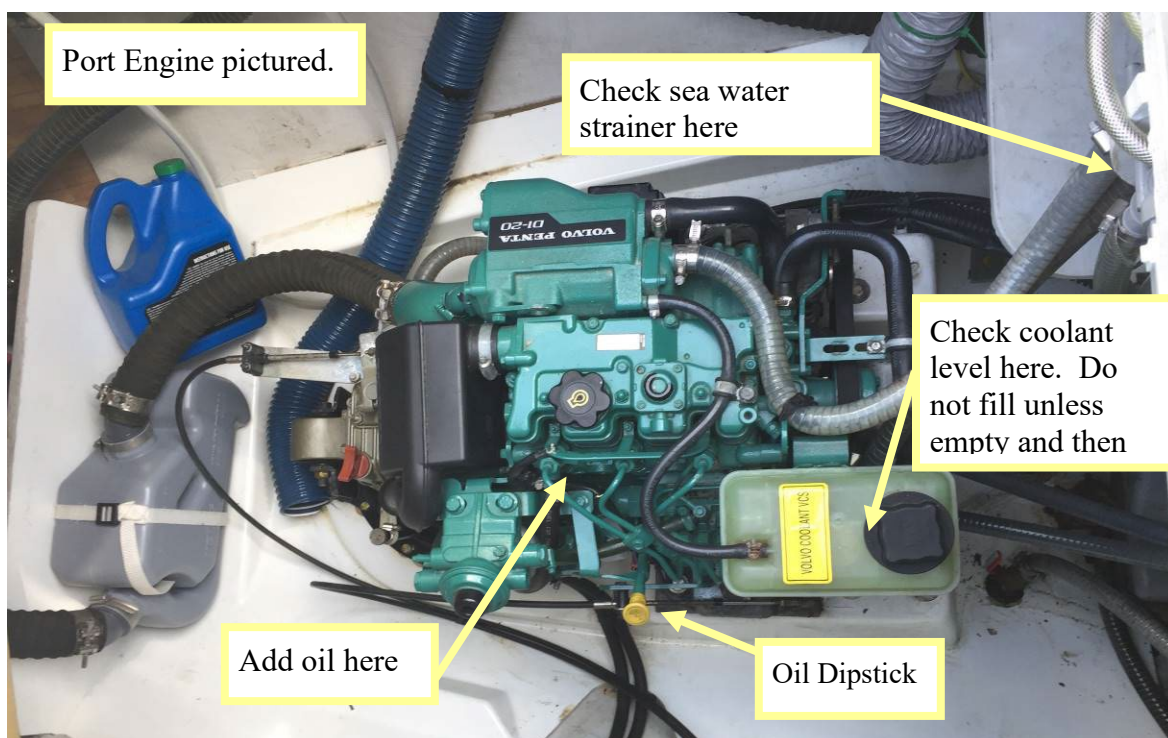

**Starting:**

- Visually check the engine, look for fluid or oil under the engine or eelgrass in the strainer. There should be no need to check the oil level unless you are out for more than a week (it is checked every turn-around by our maintenance pro).
- Make sure the gearshift is in neutral (approx. vertical).
- Push the On/Off button (upper left of panel). **It only takes a quick push – if you push it in and hold it too long it will turn on the then right back off again.** Then, once panel has booted up (takes 3-4 sec.), push the Start button (upper right).
- After she starts, check for water flowing out the exhaust.
- There is no need to warm up the engine, getting out of the harbor will do this.



**Engine Overheat** – If the buzzer sounds while the engine is running look to see if there is cooling water exiting with the exhaust and shut the engine down if you can do so safely. Overheating is the most likely cause for the buzzer (it will also alarm if you run out of fuel). It is worth checking on the oil level, coolant level, fuel level and raw water strainer. If you see something obvious and can fix it great, if not please call us or San Juan Sailing.

**Engine Shutdown** – First make sure the engine is at idle and the gearshift in neutral. Then push the Stop. You can also use the On/Off button, doing so will kill the engine and turn off the panel.

12. **Fuel Tanks and System:** The fuel tank holds 79-gallons. The emergency fuel shut-off valves are located on top of the tank which is in the starboard aft beth, remove Velcro panels on inside wall (see picture below). The fuel gauge is located above the 12 VDC panel (see picture on Electrical Systems page). However, **do not believe this gauge, it has a tendency to stick and show more fuel than may actually be there. Instead, note the hours when you leave and fill the tank if you have run 60-70 hours.** The engine hours can be viewed using the digital readout on the engine panel, see diagram above.

**When filling the tank listen closely and stop as soon as you hear fuel coming up the fill pipe.** It will foam out the vent if you go further. The deck fitting k is under the helm seat in the cockpit.

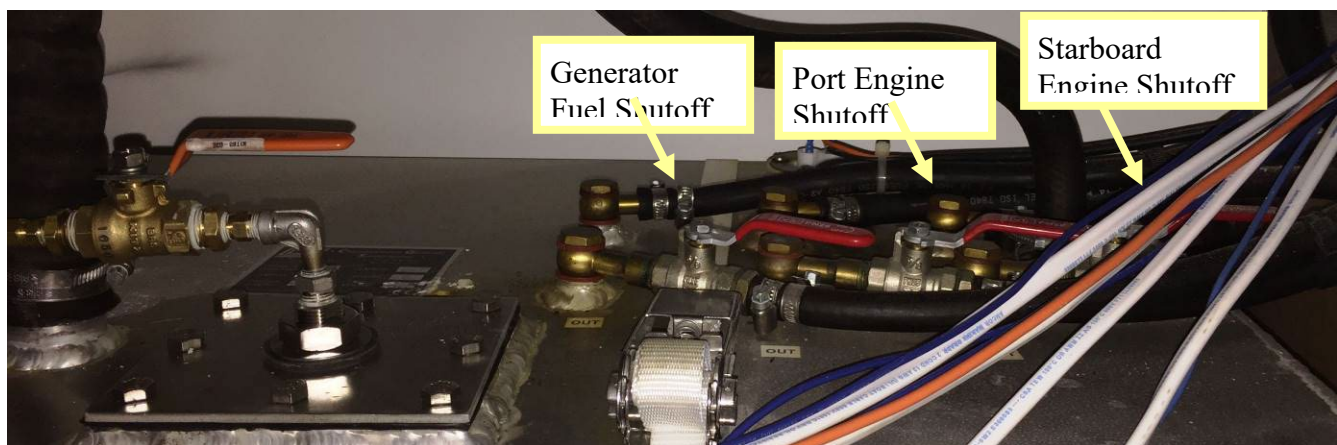

**13. Galley:** For those of you who are interested in fine dining while on vacation, we have done our best to setup Thin Air with a well-equipped galley. We have place settings for eight onboard and most of the pots, pans and utensils needed for food preparation.

**Microwave** – We have installed a microwave in the galley for convenience. You will need to be sure the inverter is on before using unless you are hooked to shore power. Also, the AC Outlets switch on the left side of the 110V Panel will need to be on.

**14. Heads and Holding Tanks:**

Please do not put anything in the toilet that has not been eaten. Experienced sailors deposit toilet paper in a wastebasket, not down the toilet because paper tends to clog the system.

Both heads have electric auto-flush toilets. **They both flush with fresh water so the water pump will need to be on for them to work.** The controls are next to the toilet, see picture on right.

Press top button to Auto-flush (adds flush water and drains bowl). Rock the bottom button left to manually add water to the bowl and to the right to manually drain the bowl.



The flushing water supply hoses have manual shut-off valves that can be closed in the rare event that the solenoid valves that are controlled by the flush buttons do not close properly and the toilet continues to fill. The valves are located in the heads inside the cabinets below the sinks. See photos on right. The blue arrows point toward the valve handles.

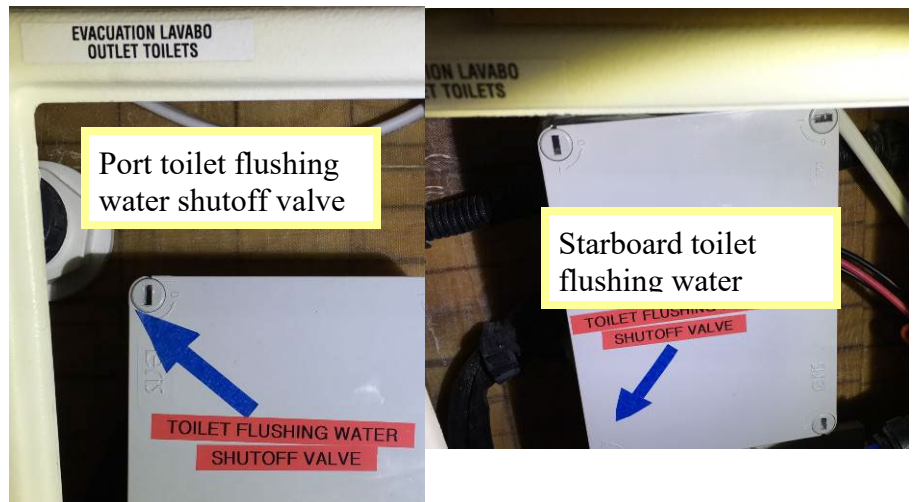

The photo above shows what the valve looks like. The valve is circled in red. The handle is on the right side in this photo.

Each head has its own 13 gallon holding tank. The tanks can then be dumped overboard (if you are in Canada) by opening the drain valves: Each head has a tank drain valve under the sink (see picture to right). Please note these are gravity drain tanks, there is no need for a macerator. They will normally drain in less than a minute (you will hear them finish with a ‘woosh’ if the engine is not running); or pump out when in harbor. If you want to pump out the tanks the deck fittings are on each side about mid-ship. **These tanks are relatively small so please dump or pump every day.** There is a level indicator for each tank that will give you an idea of how full the tanks are.



Holding Tank  
Drain Valve Red

### 15. *Refrigeration:*

**Freezer** – The freezer, which holds 90 liters, is wired directly to the batteries and the thermostat is in top of the freezer compartment (see picture). **We normally leave the unit running 24 hrs a day without battery issues.**

**Refrigerator** – The refrigerator is a two-drawer model with about 150 liters in volume. There is a breaker for the frig on the main panel and the controls are on the top front of the frig (see picture below).



Thermostat

On/Off



Thermostat

Freezer

**16. *Repairs (Tools & Spares):*** It is our goal and hope that you will not need to make repairs during your trip. That being said, we have also provided a good selection of tools and spares in case you need them. The tools are stored in compartment under the port side of the dinette. The spares are stored under the nav seat or the starboard side of the dinette. If you have problems that you are not comfortable handling please call us or San Juan Sailing (see numbers on page 1)

### 17. *Sails and Rigging:*

**Mainsail** – Thin Air sails quite well for a cruising cat and point higher than most. But, like most cruising catamarans, she has a very large main sail which can over power the rudders. Therefore, it is important to keep the main sheet in a state where it can be released should you need to fall off.

#### **Raising:**

- a. Unzip the lazy bag.

- b. Steer head-to-wind and maintain course.
- c. Attach the halyard to the head of the sail (make sure the halyard isn't twisted)
- d. Be ready to release mainsail sheet when preparing to hoist the main.
- e. Then, use the electric winch to raise the sail. Put 4 wraps around the winch so the line doesn't slip, the winch is very powerful (Don't over-crank on the winch or the sail could possibly rip somewhere along the luff).
- f. Watch that the sail doesn't get caught in the lazy jacks
- g. Fall off and you're sailing! (Now you're ready to deploy the head sail.)

**Reefing** – Even though they do not heel very much it is important to reef a catamaran's sails in stronger winds. The reason has to do preserving the sails. On a mono-hull a puff of wind will heel the boat a bit further, but on a cat the sails take the brunt of the added force since it is so hard to heel the boat. Therefore, use the following list as a guide:

- Apparent Wind Speed up to 24 knots. Use full main and full jib
- Apparent Wind Speed between 25 to 29 knots. Use 1st reef in the main and full jib.
- Apparent Wind Speed between 30 to 35 knots. Use 2nd reef in the main and 60% jib
- Apparent Wind Speed over 35 knots. Use 2nd reef in the main and no jib

The only thing unusual about reefing the main is the tack attachments. The picture below shows the shackles which are used to hold the nylon straps which feed up through the cringles from the far side of the mast to this side.

**Headsail** - Please keep moderate tension on the roller furling line when deploying the headsail to prevent a rat's nest on the drum. Similar tension on the sheets should be used when furling to prevent 'candy striping' of the furled sail.

**Electric Winch** – The electric winch should be used primarily for sheeting in the main sail or raising the main. IT SHOULD NOT BE USED TO ADJUST FURLING OR OTHER LINES. It is too powerful and can easily break sails, lines or fittings, all of which will break before the winch does. The winch circuit breaker is located in the port engine compartment.

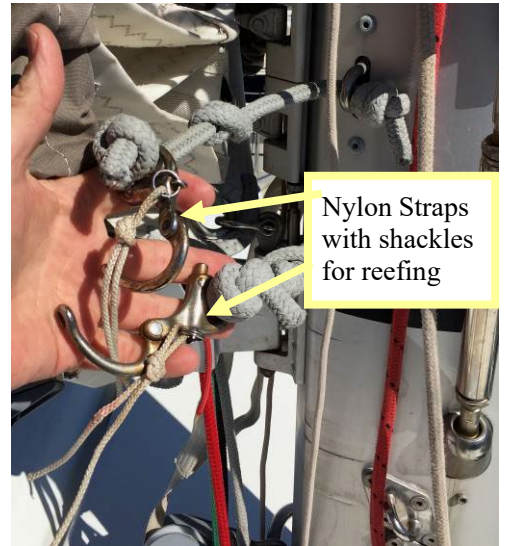

18. **Showers:** Experienced cruisers know the sailor's shower: get wet, turn it off, soap up, rinse off. **CAUTION: THE ENGINE CAN HEAT THE WATER TO SCALDING TEMPERATURES!** Each shower has a sump pump with a switch located in the shower area. Each shower has a sump pump to drain the flow, each time you press the button the pump will run for 30 seconds.





There is also a shower fixture back on the port swim platform. This is useful for washing off shoes after returning from the beach. This fixture is located on the transom to port of the aft storage locker.

## 19. *Stove:*

Thin Air has a propane stove with three burners and a separate oven. Propane is heavier than air and requires caution. For your safety, please follow these procedures:

- a. Make sure all stove controls are in the “off” position. As with the BBQ, having the stove valves open when the solenoid is opened will cause the safety system to kick in. This will severely limit the flow to the stove. If this happens close all the valves, including the one on top of the tank. Then open the tank valve first.
- b. Turn on propane solenoid valve switch on the electrical panel.
- c. Light a match or the butane lighter and push in the stove knob and turn to high. The burners will take a while to light on the first use. When the flame lights, hold in the knob for about 3 seconds to allow the thermocouple to sense the flame.
- d. When you are finished with the stove turn the solenoid switch at the panel off.



To light the oven you will need to push in and turn the “oven” control knob on the front of the stove. Then put your butane under the bottom metal “floor” of the oven. You should hear the burner ignite. If you have trouble lighting it, remove the metal floor/bottom of the oven, exposing the U-shape oven burner. You’ll easily be able to light it when exposed. Replace the metal floor/bottom after it is lit.

Please note that both propane feeding the stove and oven are located under the forward seat the cockpit table. San Juan Sailing’s staff fills the propane tank every 3 weeks. One tank normally lasts 4-6 weeks and Thin Air has two tanks (one connected and a spare).

## 20. *Water:*

***Water pressure*** – The water pressure switch is located on the electrical panel. Please switch this off when motoring or sailing. You could burn out the water pump should one of the tanks run dry (and you would not hear the pump running over the sounds of motoring or sailing). There is a pressure accumulator so you will be able to get some water even with the pump turned off.

***Water tanks*** – The water tank holds 140 gallons. There is a level gauge on main panel. The deck fitting is on the front deck, just starboard of the anchor locker.

***Water Heater*** – The water is heated automatically when the engine runs under load (it takes about 45 minutes), running it at idle in the morning doesn’t work, sorry. **CAUTION: THE ENGINE CAN HEAT THE WATER TO SCALDING TEMPERATURES!** The hot water is stored in a 10-gallon tank located under the dinette seat just in front of the galley. It can also be heated electrically when shore power is available. The switch is located on the AC panel.

**21. *What's Unique about Thin Air:*** In many ways she is similar to other charter boats. Therefore, you are likely to find most of her systems will be familiar and easy to operate. There are a few things about her that are not 'typical'. These are the things that may require special attention or where it may be best to deviate from customary operating procedures. And, some are listed here because we believe they will help you plan your charter.

***Steering Under Sail*** – Like most catamarans, Thin Air has relatively small rudders. They are not large enough to over-power the main sail when going to windward. If you need to fall off for some reason you will need to sheet out the main in order to maintain steerage. Therefore, we recommend having the main sheet available and ready to be let out quickly.

***Prop-Wash*** – Thin Air's rudders are placed in front of the sail drives, therefore prop-wash can only be achieved using reverse thrust.

***Operating the Engine in Reverse*** – Extra caution must be taken to hold the steering wheel and the rudders in place whenever the engines are placed in reverse – usually with your foot, knee, or body. Failure to keep the rudders and steering wheel centered while in reverse will cause damage to the steering mechanism and the rudders.

We hope this information helps. Have a great time!